

status of ATTPC

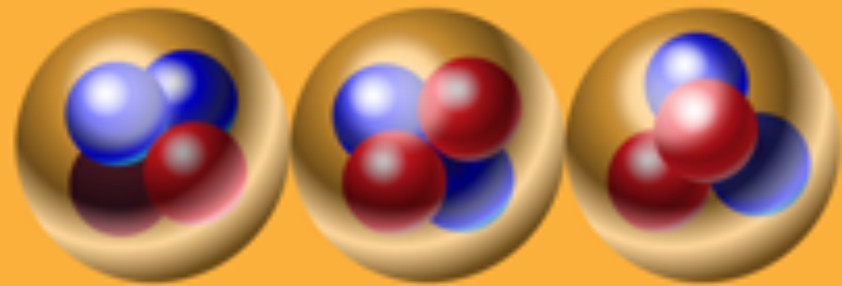

Outline

- Status of prototype ATTPC
- Design for main experiment

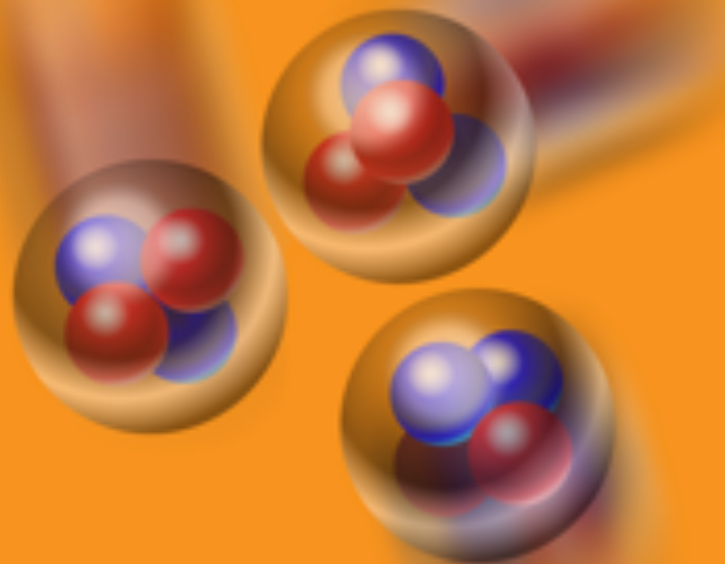

Courtesy of APS

Yongsun Kim
LAMPS meeting
2020.5.15

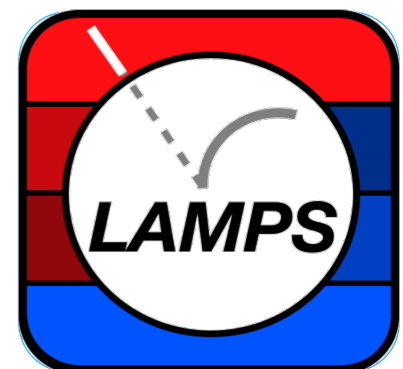

Schematic design of prototype detector

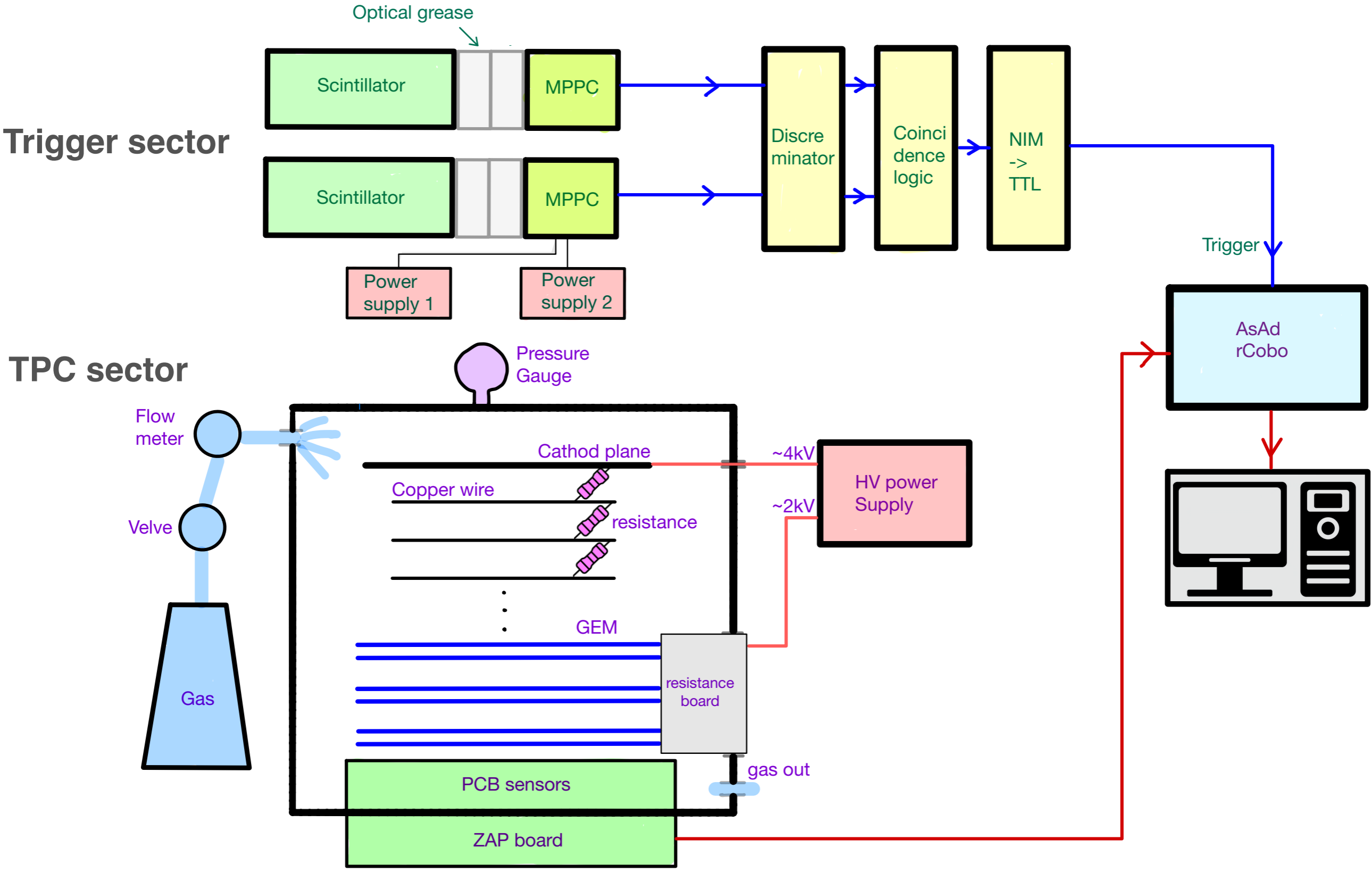

Items to be setup and tested

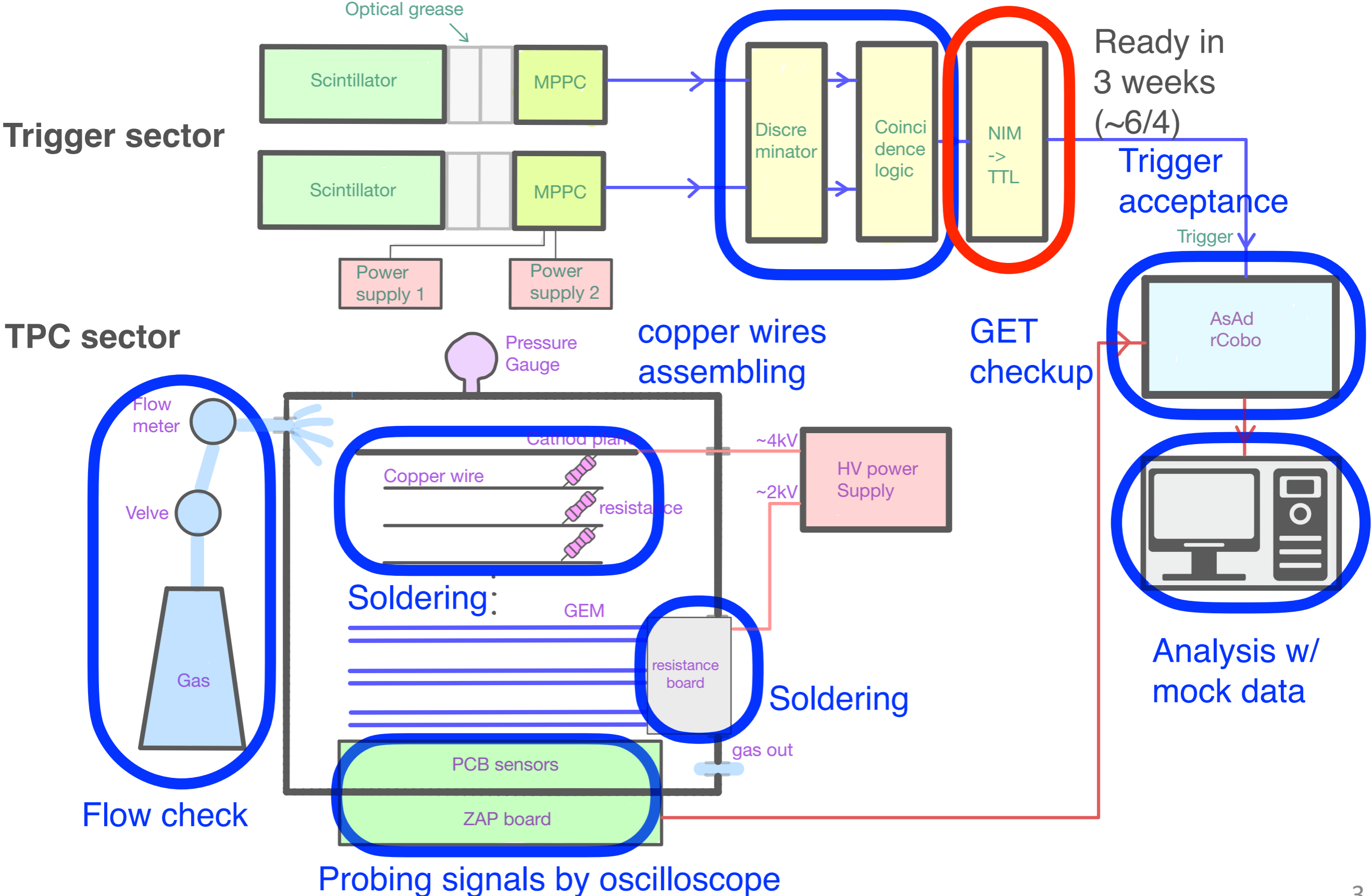

NIM modules

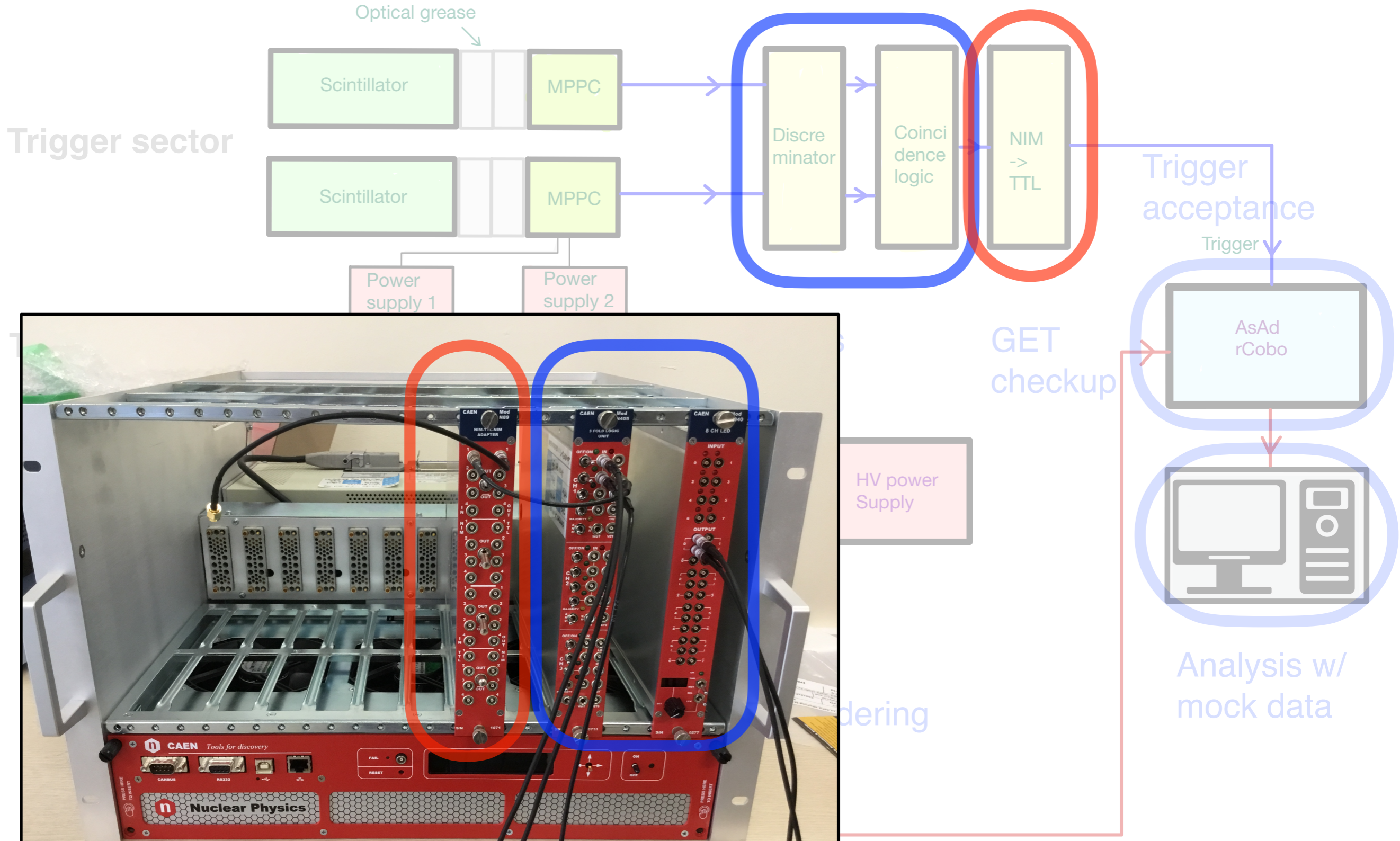

Items to be setup and tested

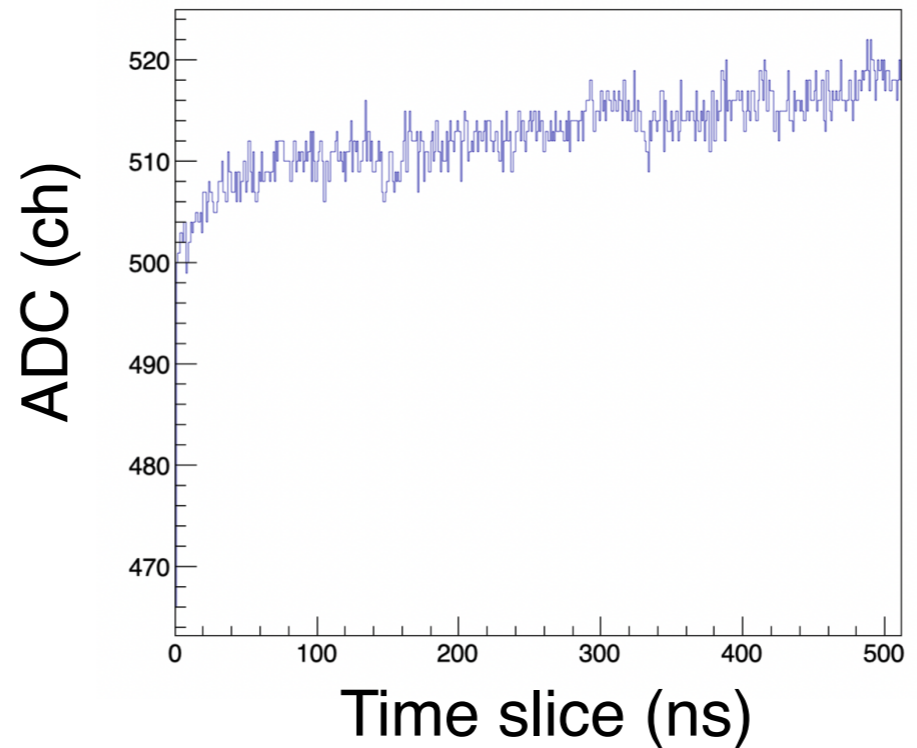
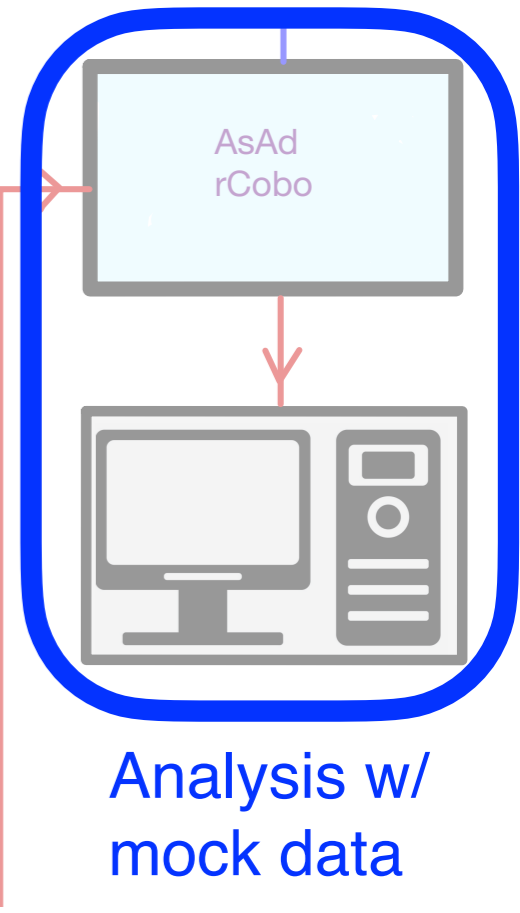
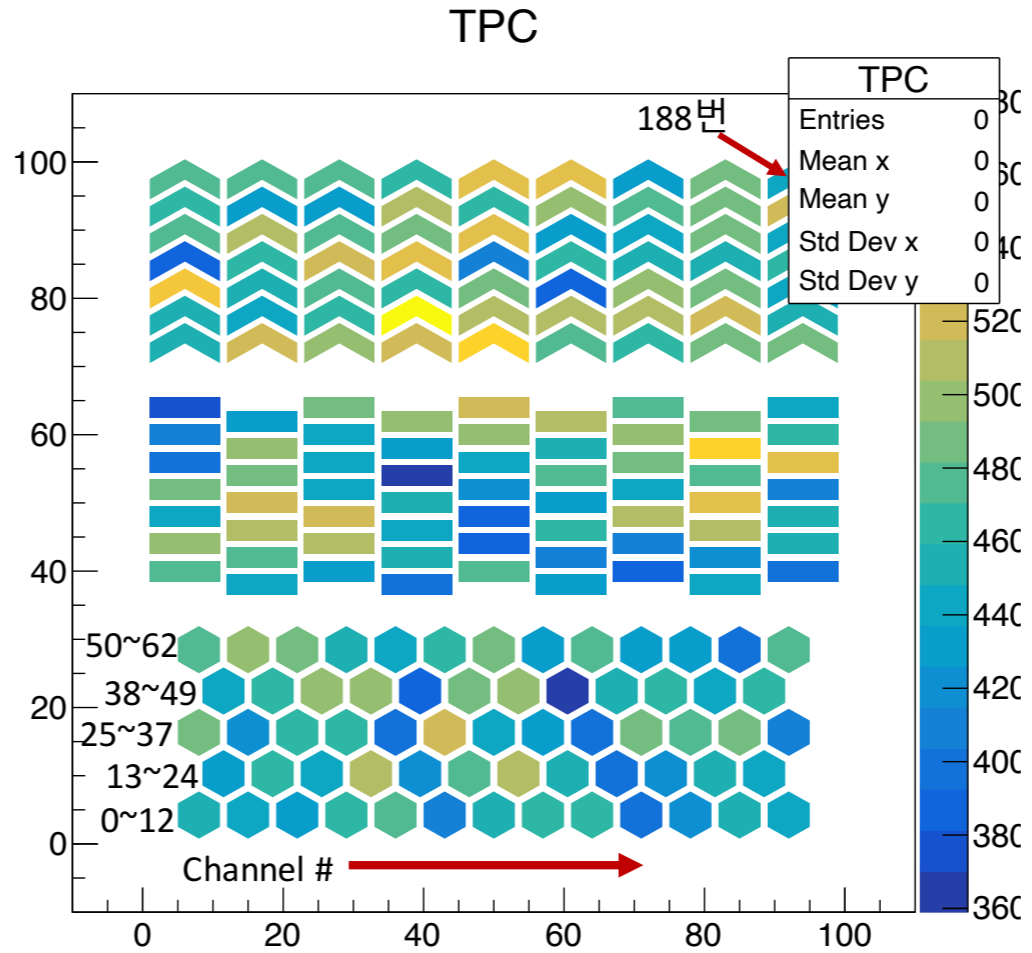
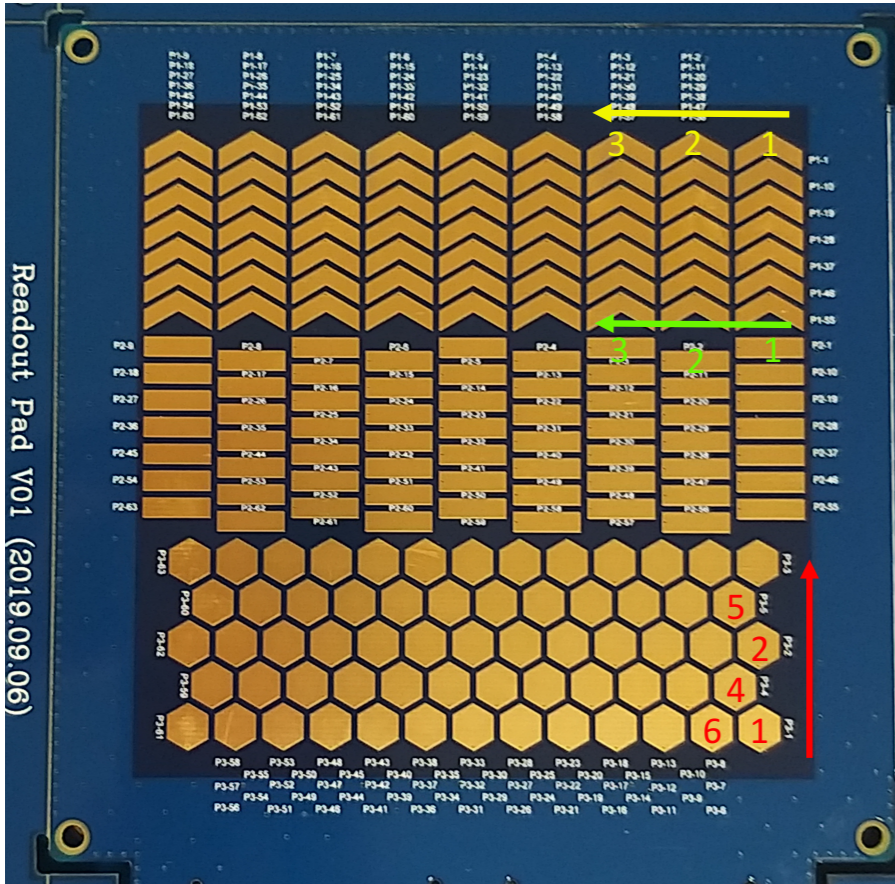

Items to be setup and tested

Trigger sector

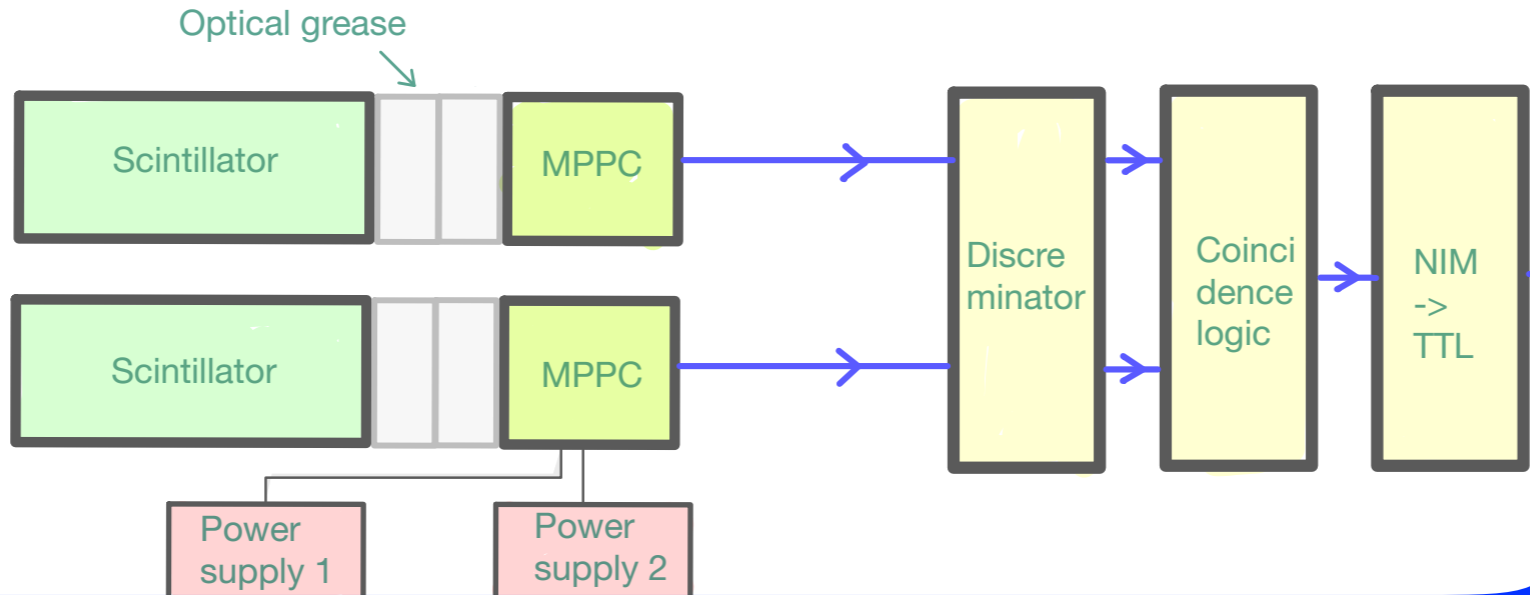

TPC sector

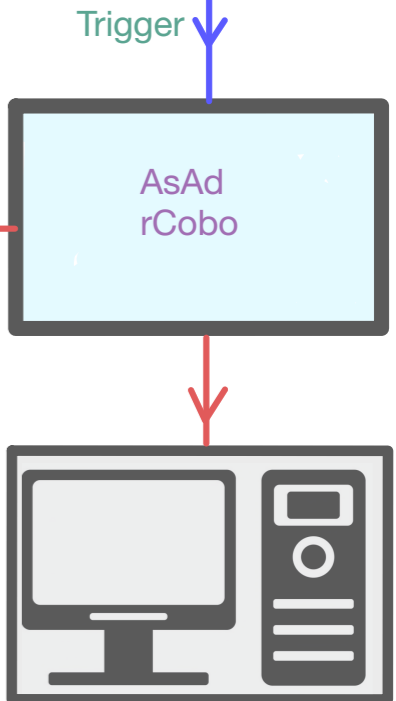
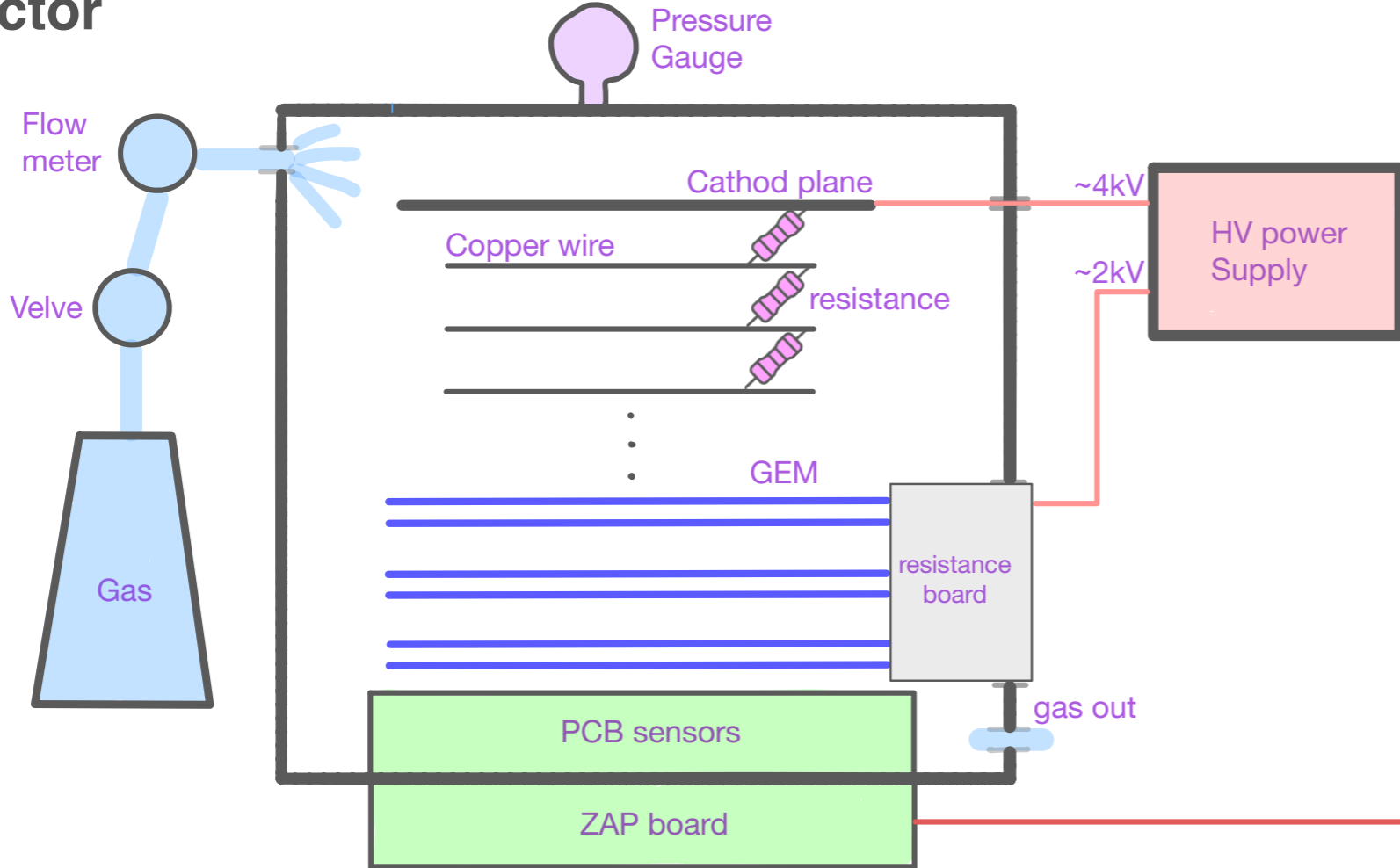

Items to be setup and tested

Trigger sector

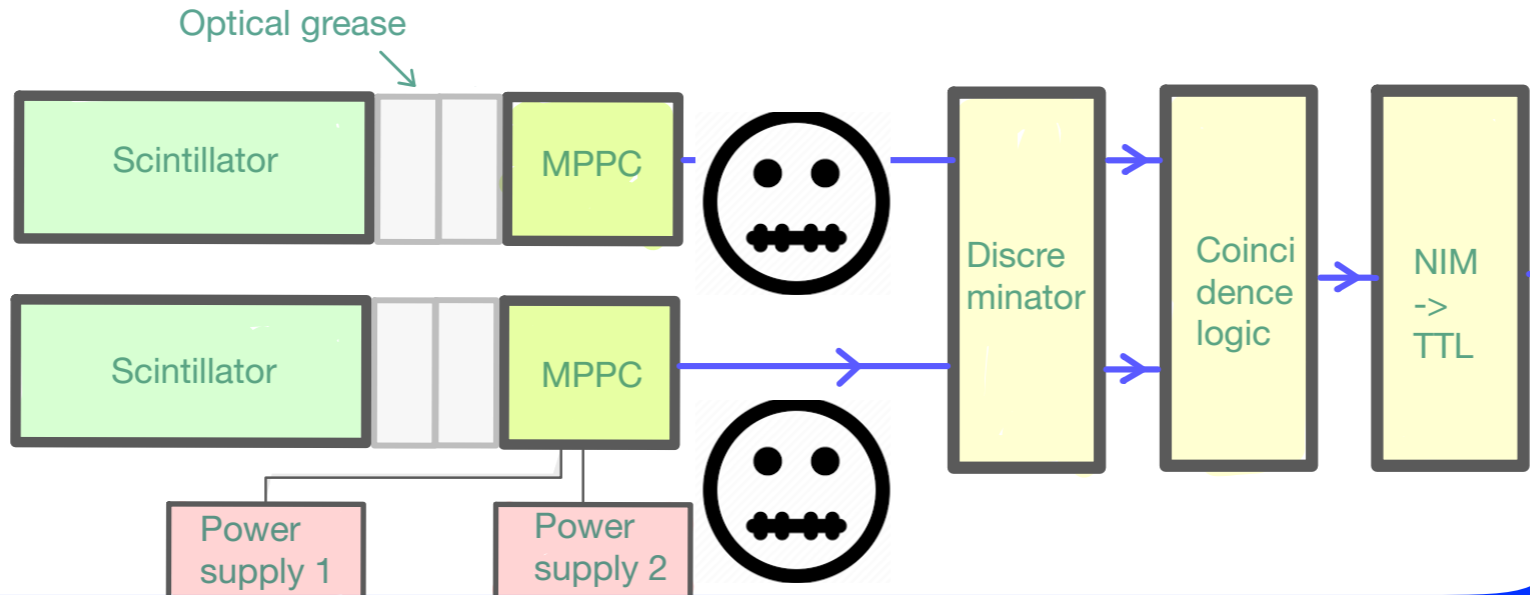

MPPC will be replaced by PMTs

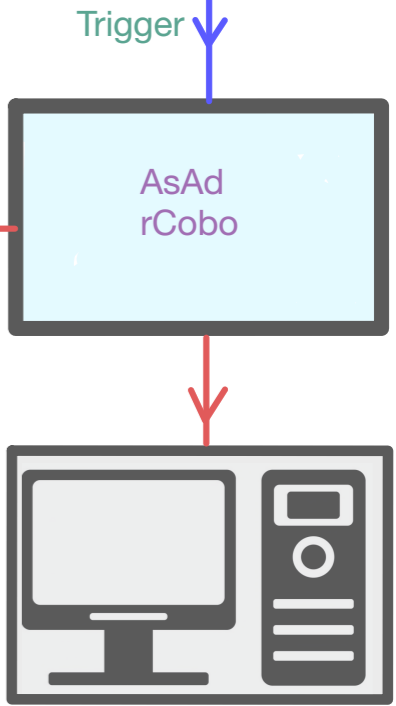

Status of gas chamber

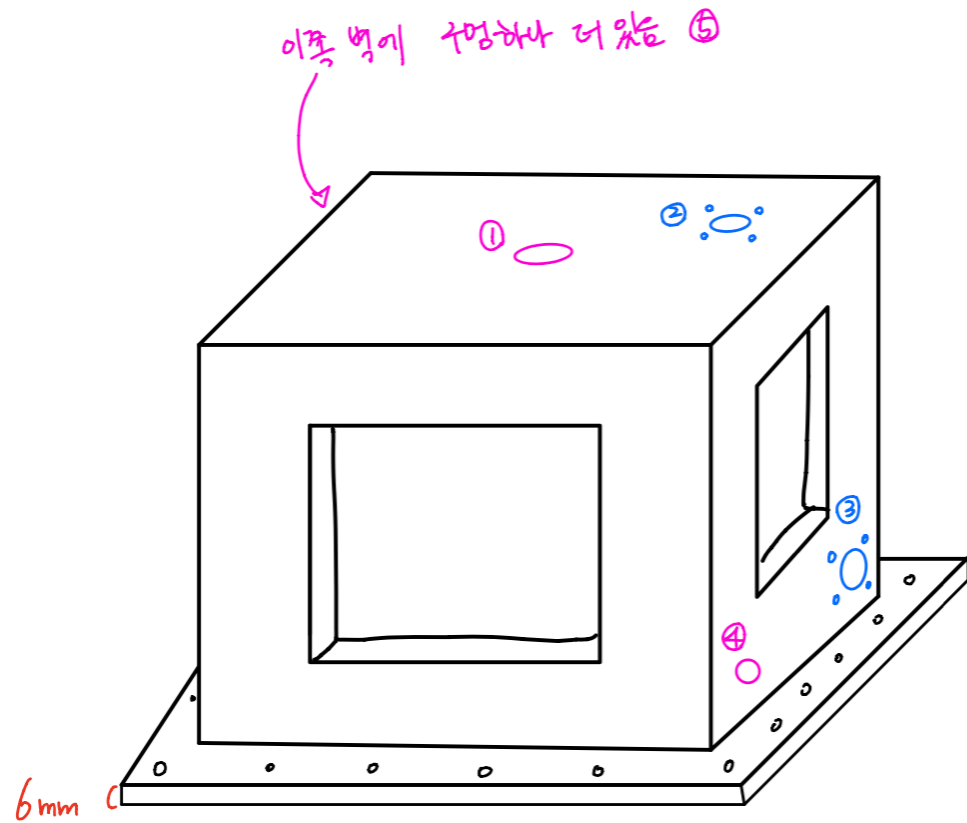

- ① 기압계 1/4" PT 규격
- ② & ③ HV Cable
- ④ & ⑤ Gas in/out 1/4" PT Fitting

- * The hole for the pressure gauge is slightly off from the standard 1/4" PT size, so we decided to use an adapter.
- * Welding for aluminum board need adapter to cope with the short thickness
- * Similar modification for the HV cable path

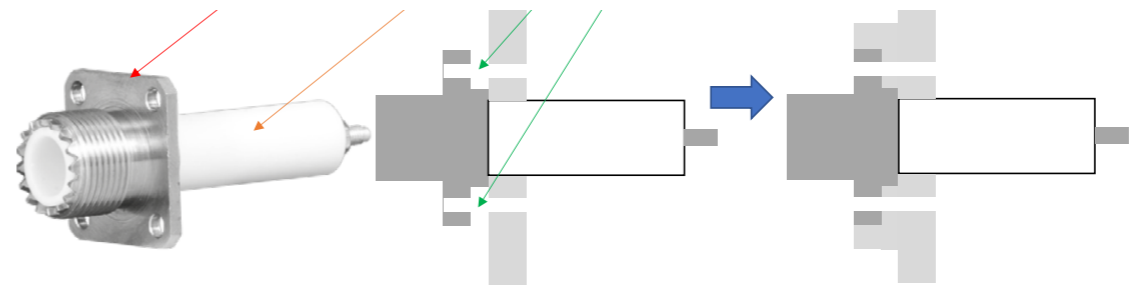
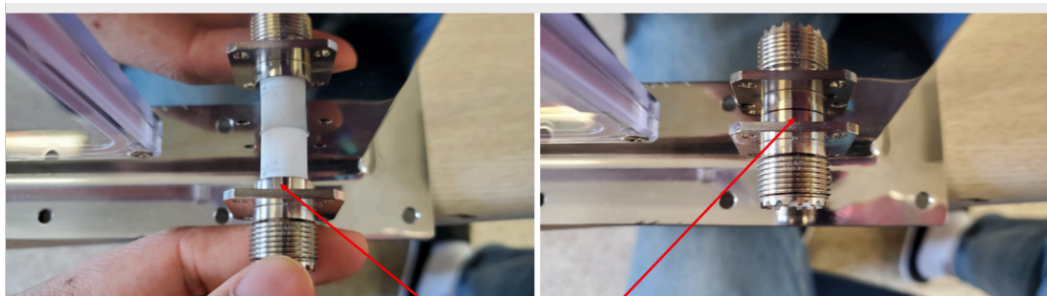
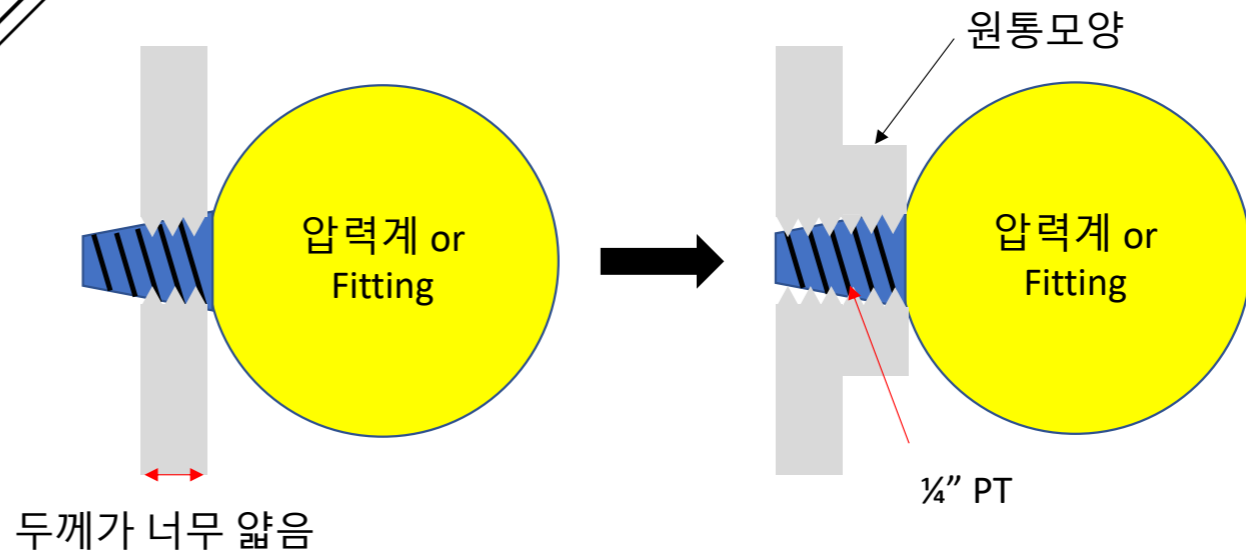

* High-voltage cable path