

Current status of LAMPS TPC

Lee HyoSang

LAMPS meeting

2016.07.20

prototype TPC muon test system



muon track

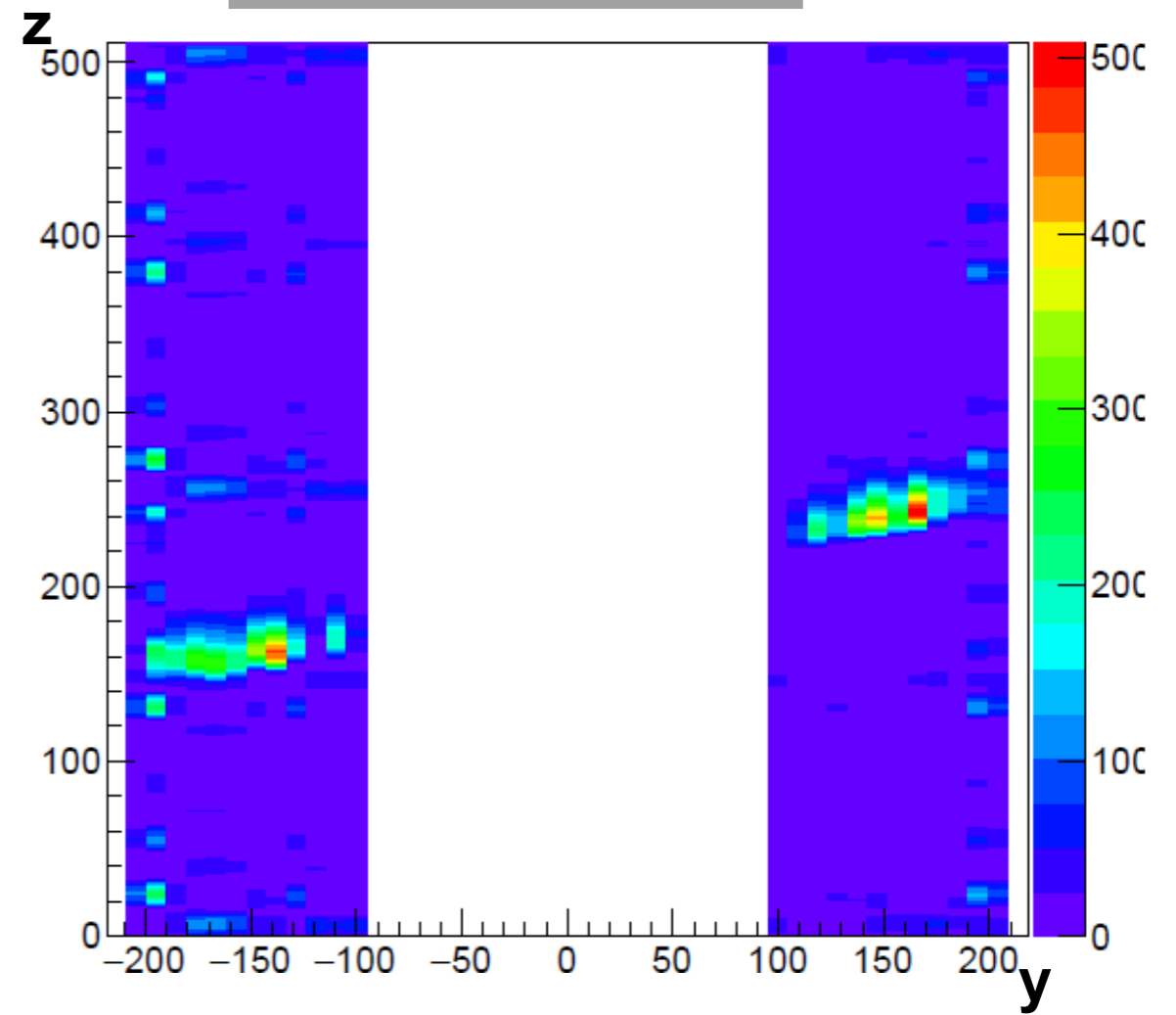
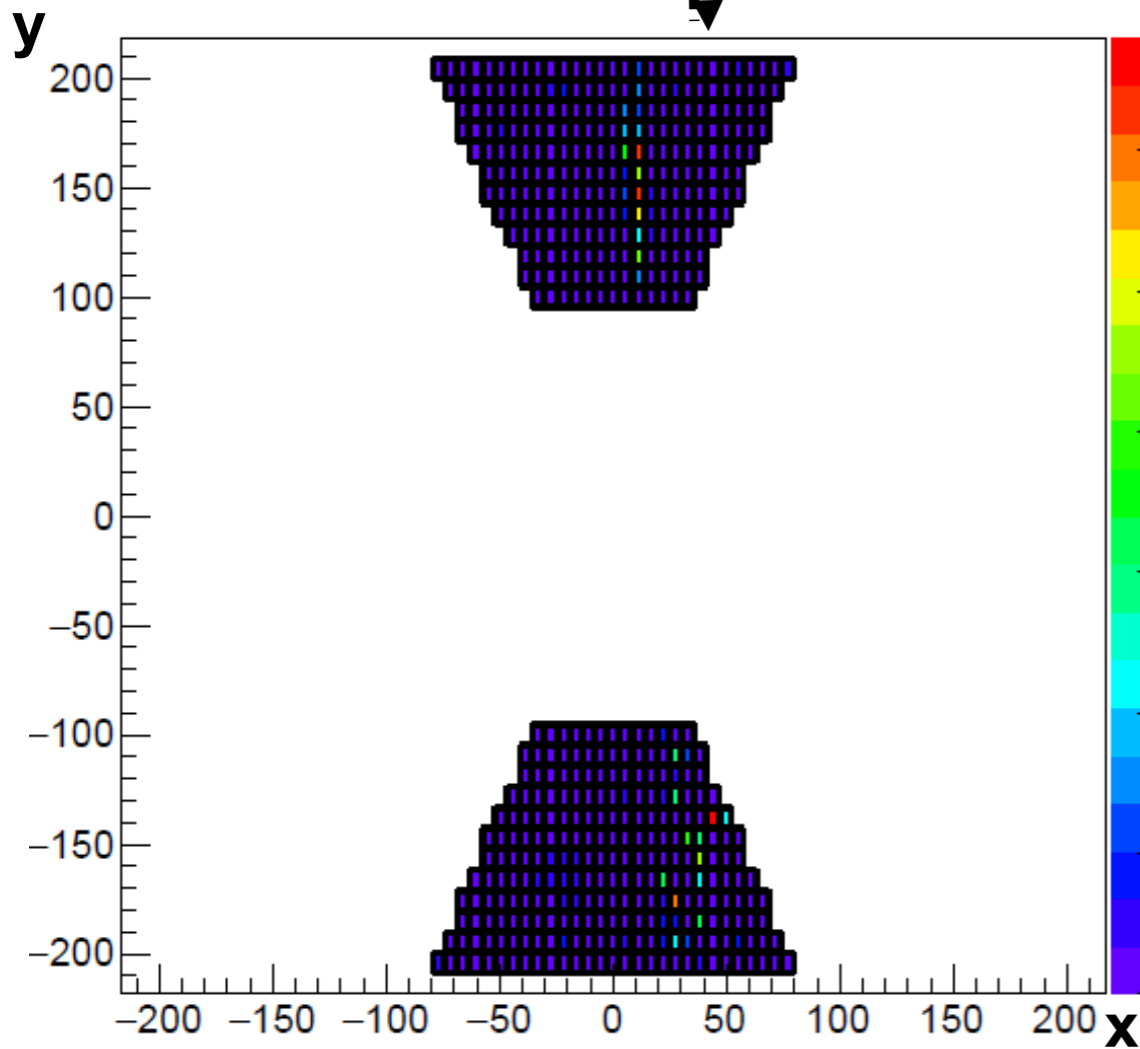
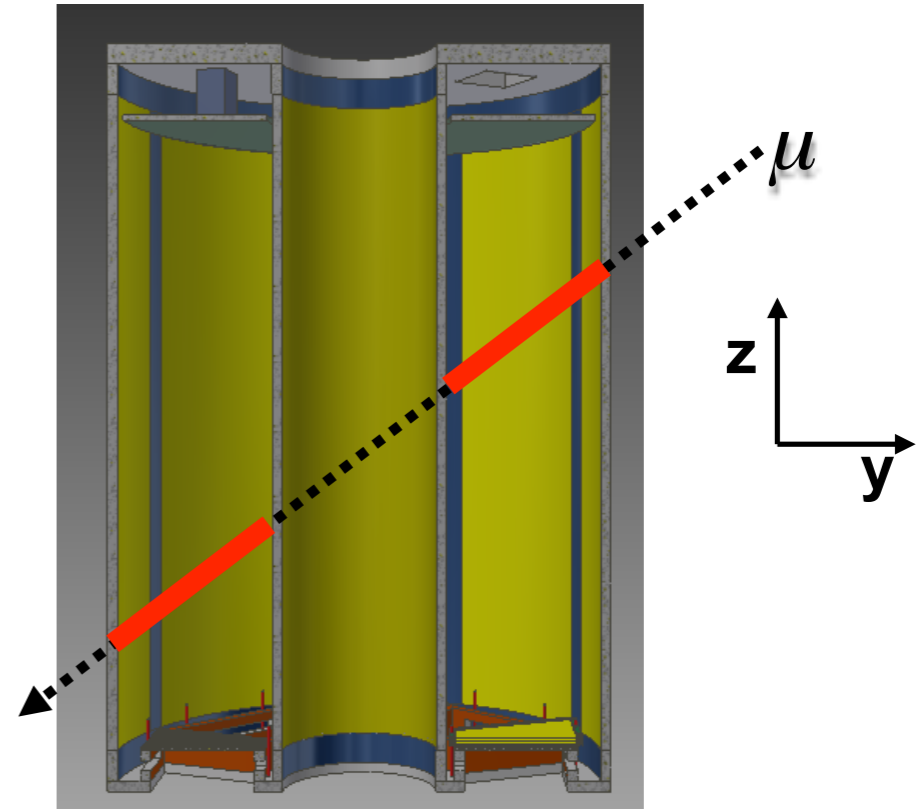
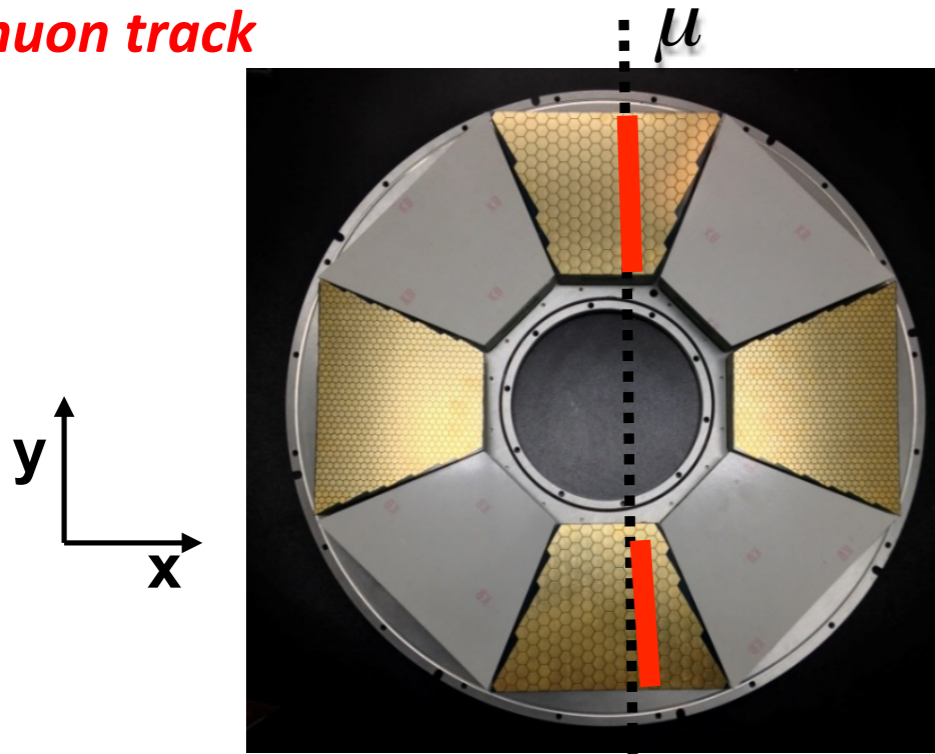

electronics problem

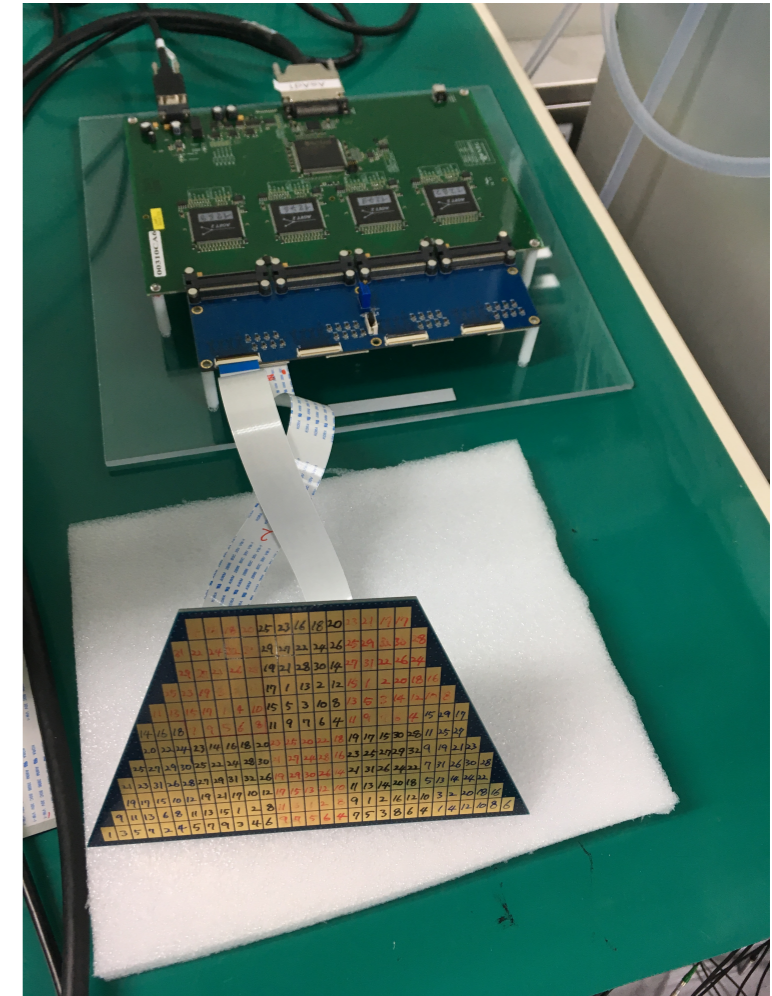
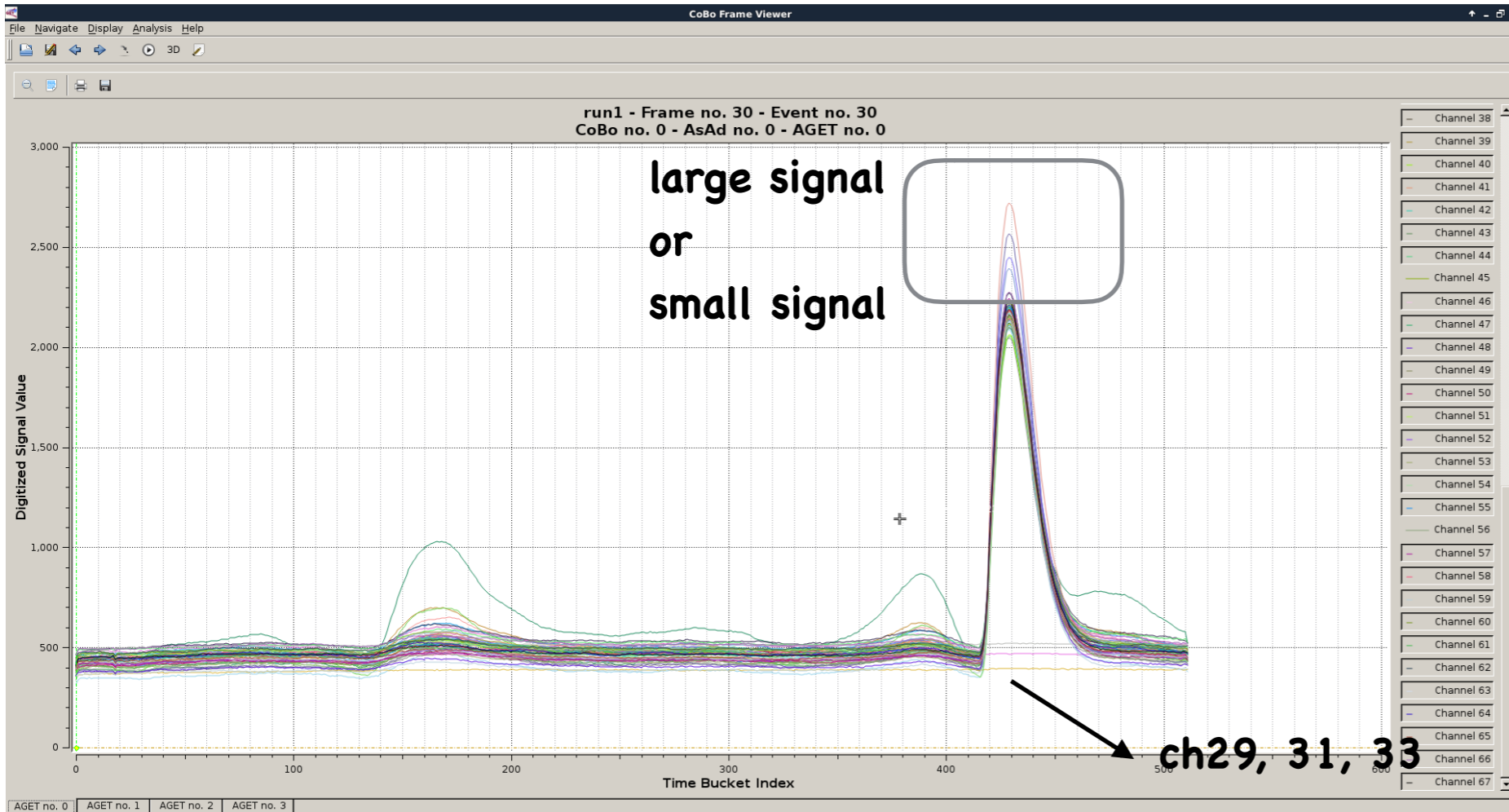

example with internal pulse
: ch29, 31, 33 have no signal.

AsAd + ZAP

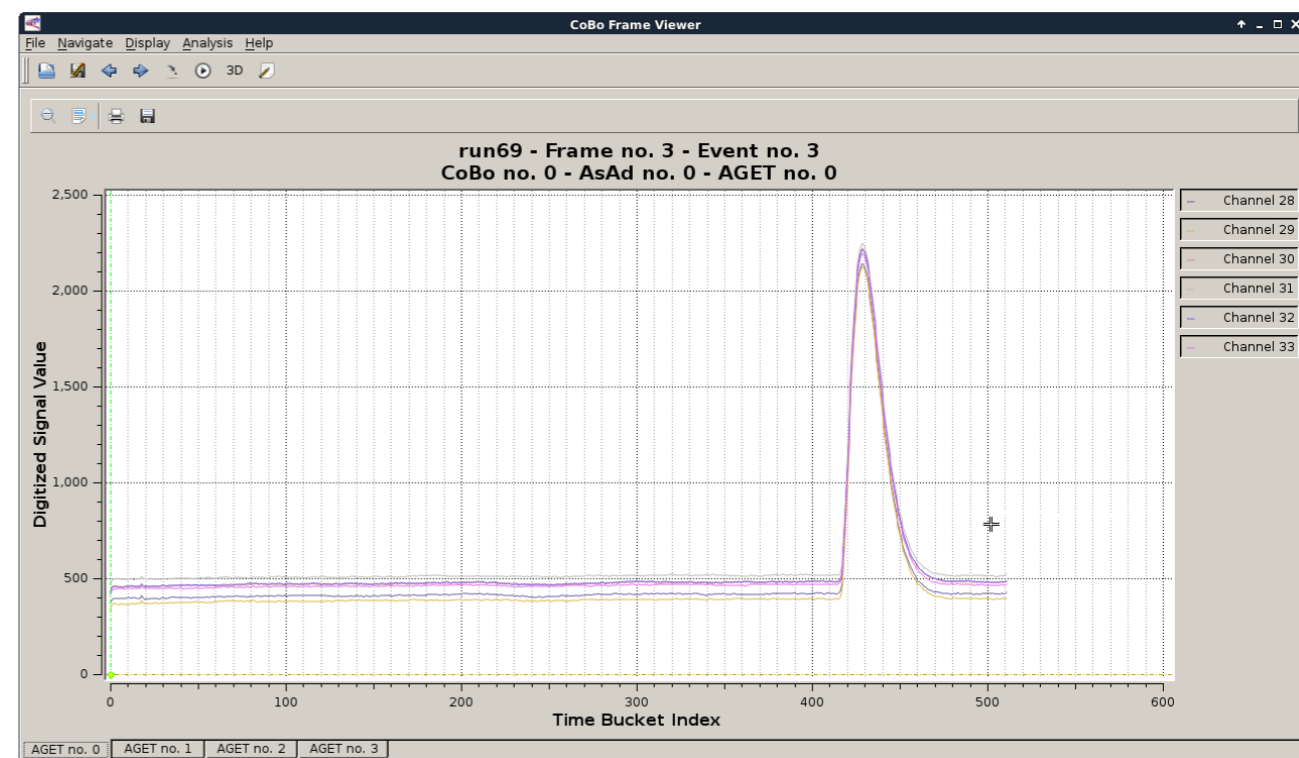

example

ch33

ch1

PAD

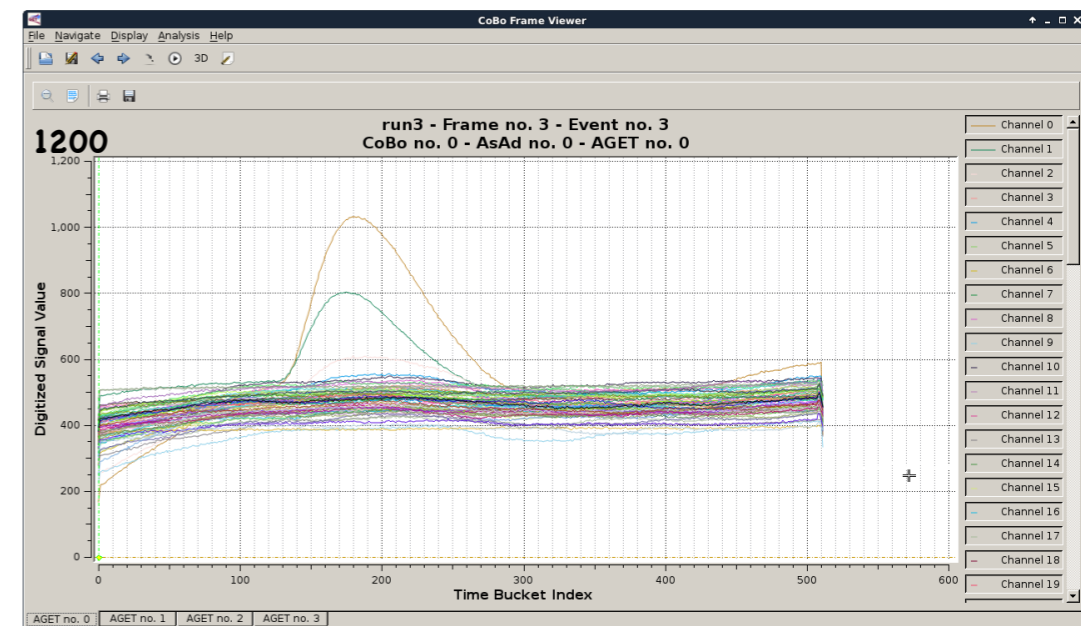
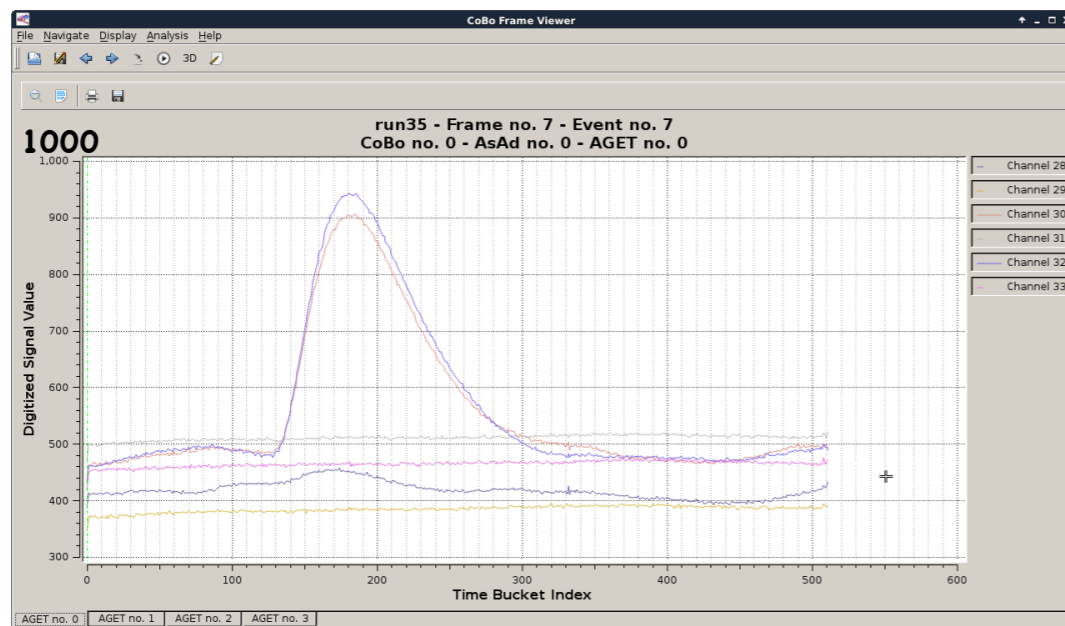

cable

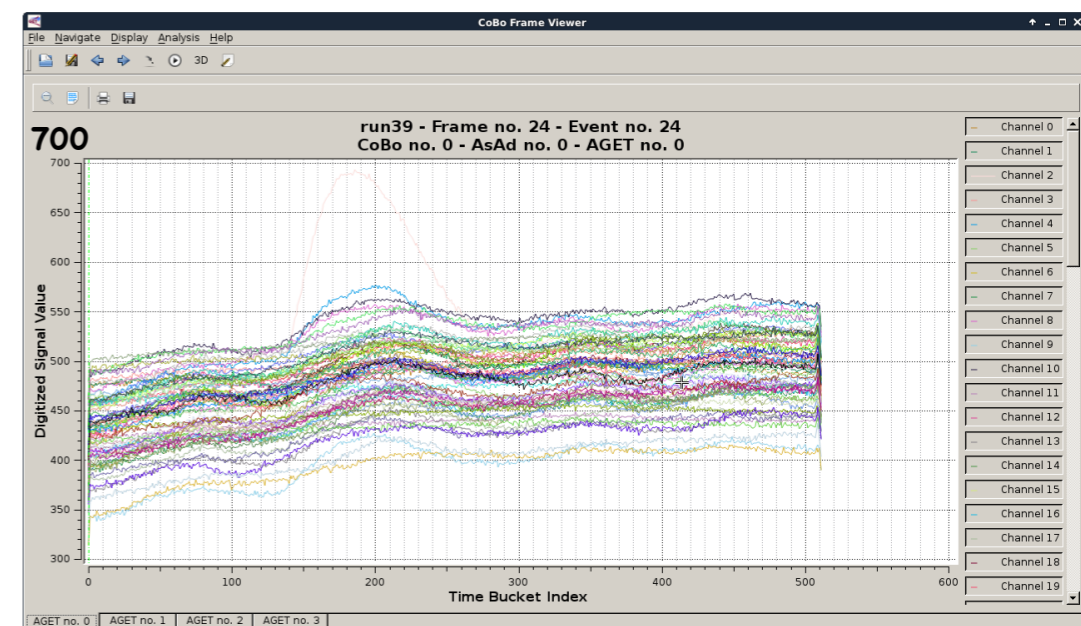
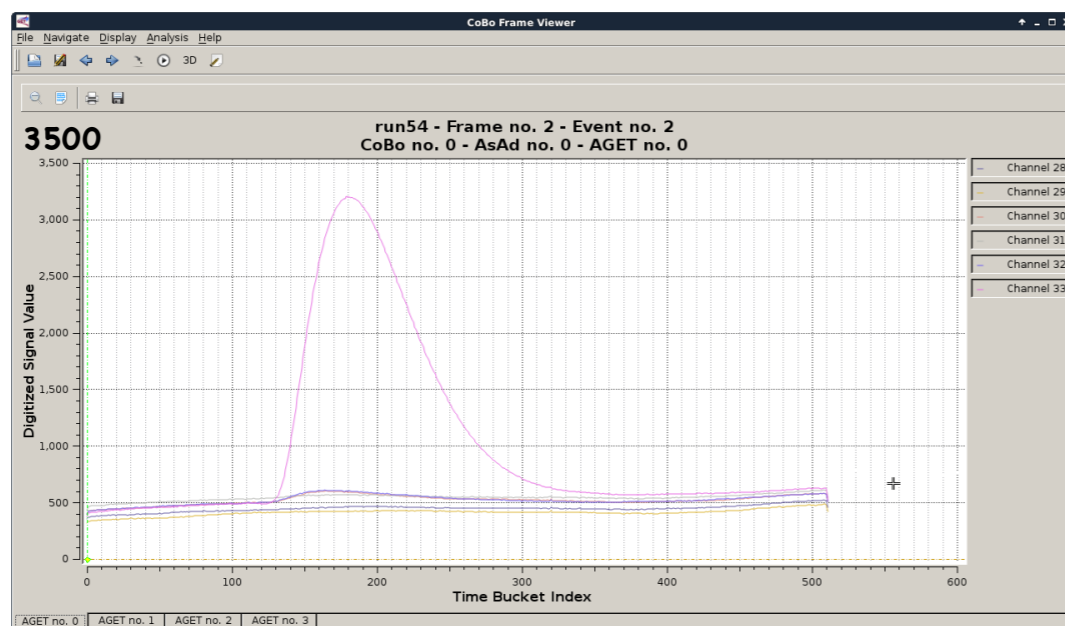

cable+connector

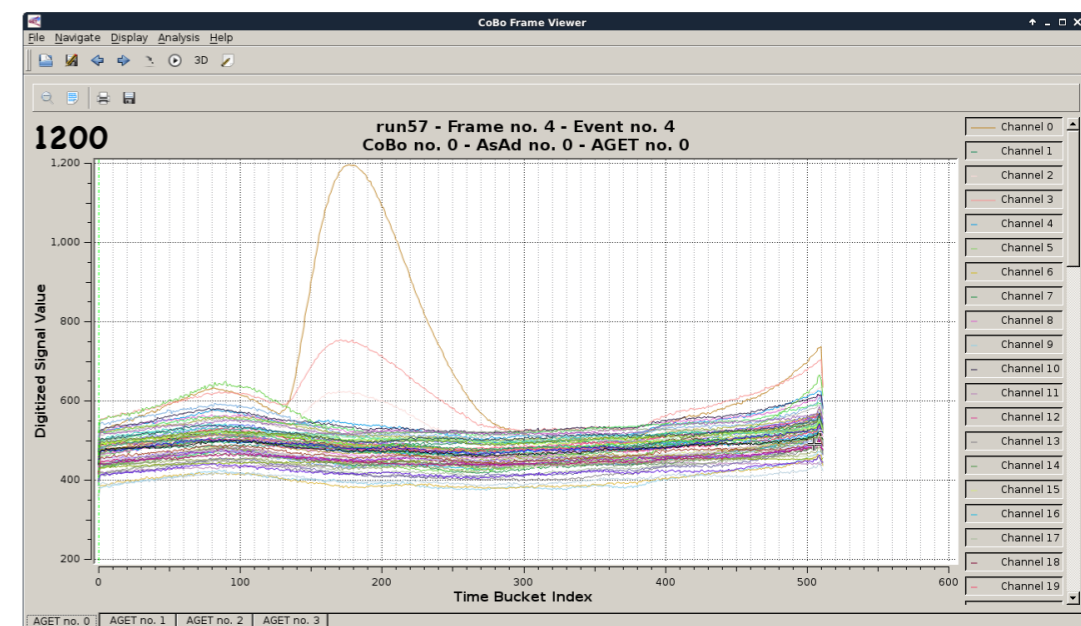
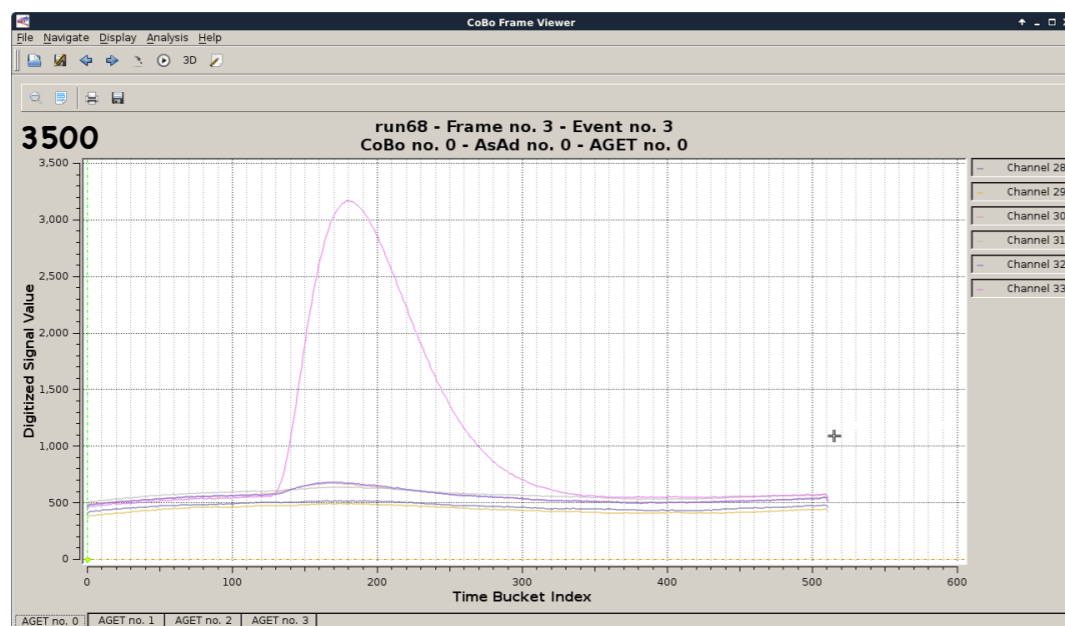

idea for new PAD & ZAP

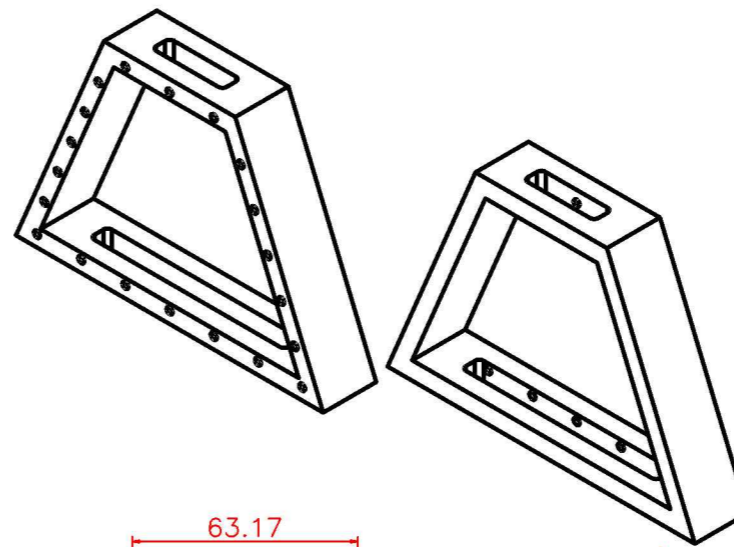
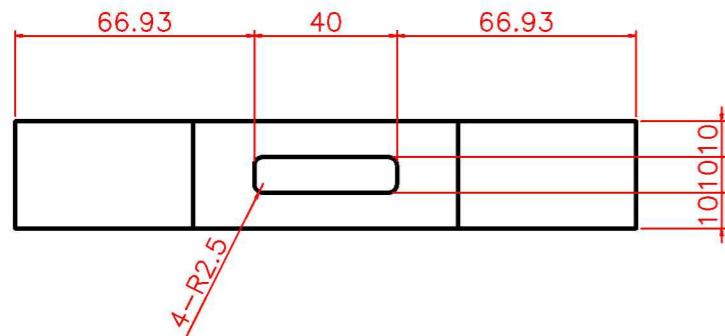

20-M4 x 0.7 x 10
DR / 15
헬리코일적용

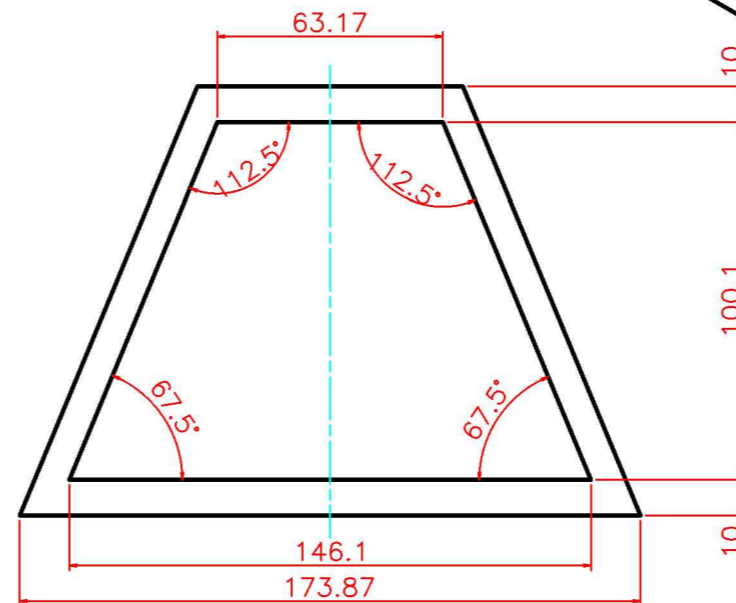
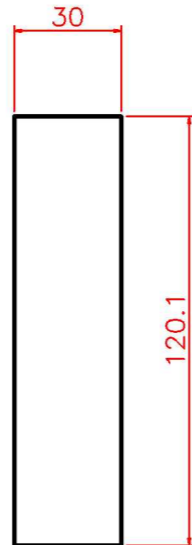
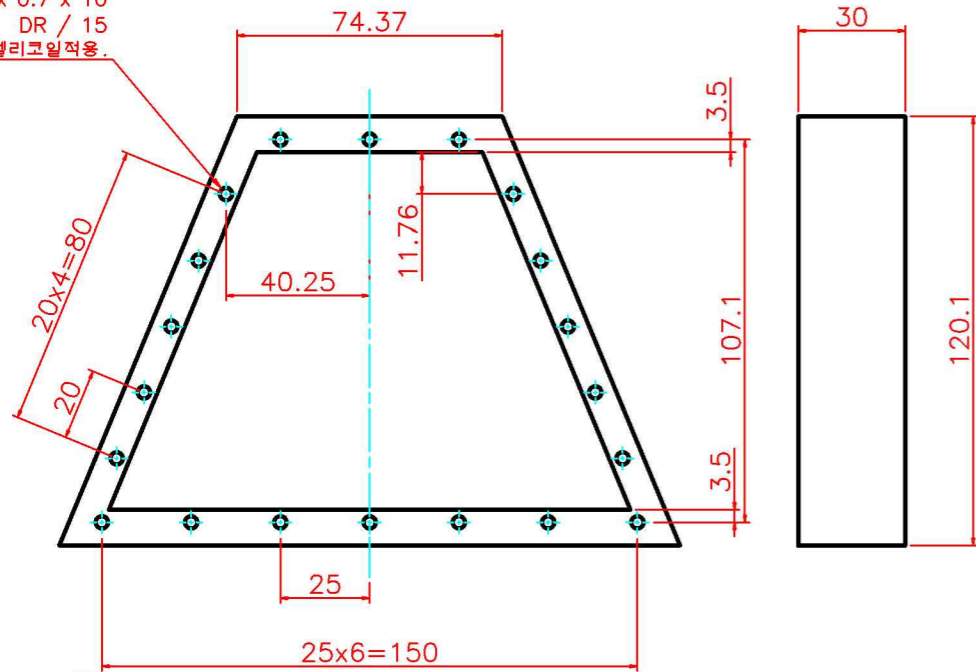

전체수량: 8ea

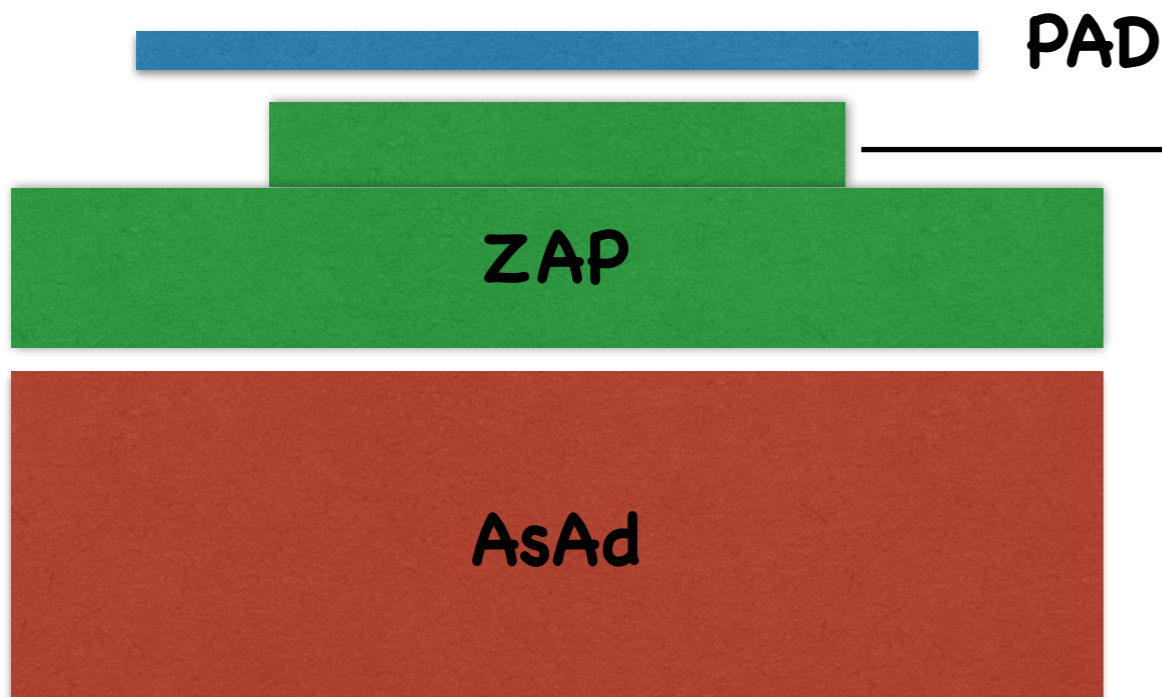

128ch x 2connector
connector : 0.8pitch or 1.0pitch?

Plan

prototype TPC

channel problem

new PAD & ZAP

muon test : tracking, drift velocity ...

muon test with magnet

triple GEM test

as gap size

field cage test

Mutant test