

RCNP experiment

Hyunha shim

2016-5-1

RCNP Exp detector structure

- 1st station : 10cm*10cm*100cm 2개
- 2nd station : 10cm*10cm *200cm 4개
- 3rd station : 10cm*10cm*20cm 4개

Veto 50cm*50cm*1cm 1개

total # of detectors : 11개,

total # of PMT : 18개

Experiment environment

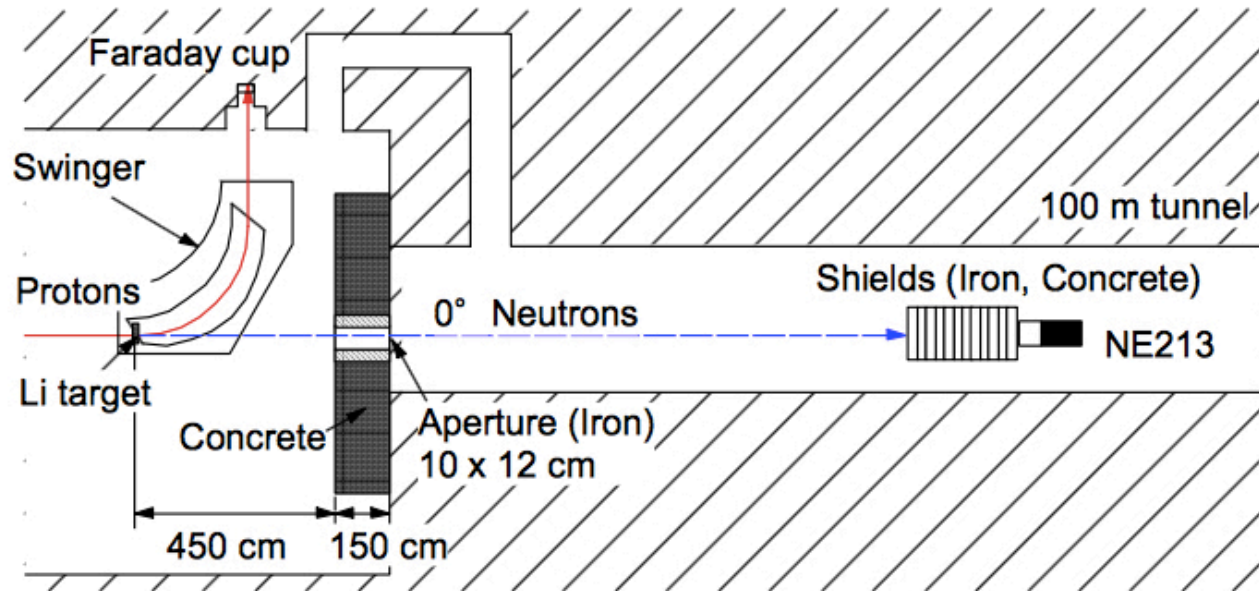

실험에 이용할 중성자 에너지 : 65 MeV, 390 MeV

Beam current : 1 μA ($\sim 2 \times 10^6$ neutrons/s)

Yield and energy of peak neutrons are $\sim 0.96 \times 10^{10} \text{ sr}^{-1} \mu\text{C}^{-1}$ and 387 MeV for the 389 MeV pri

Number of background neutrons above 3 MeV is less than 1%

Simulation structure

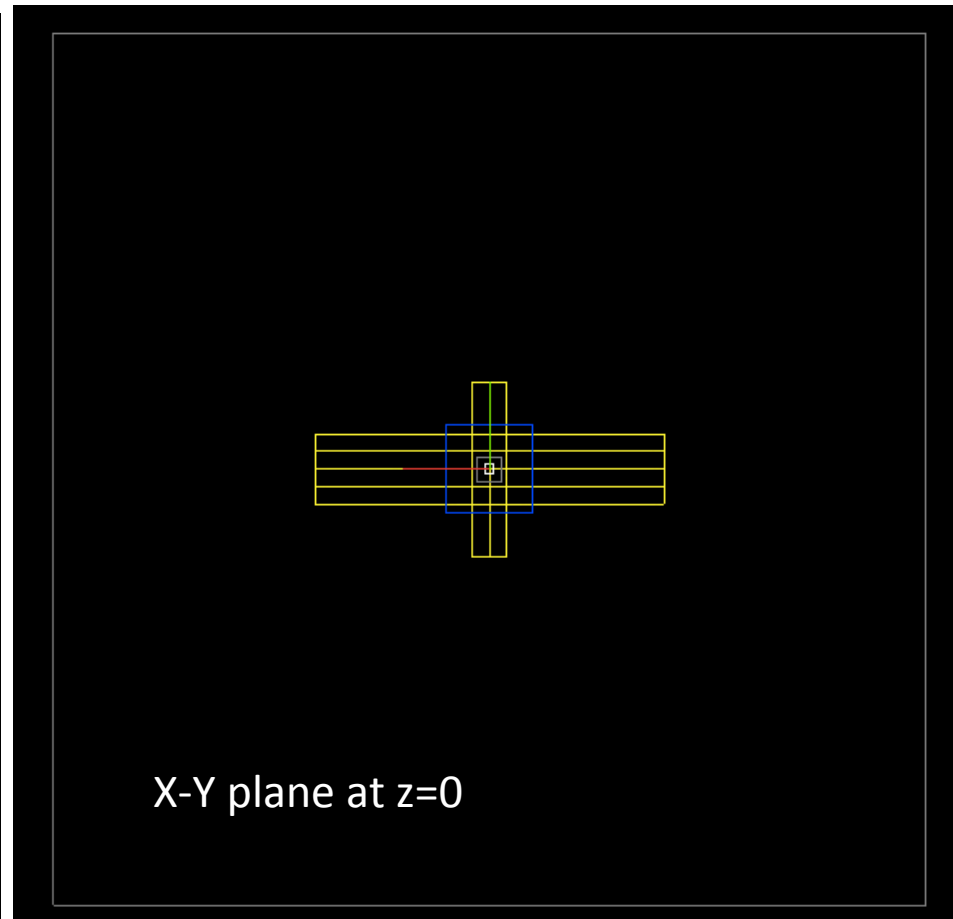
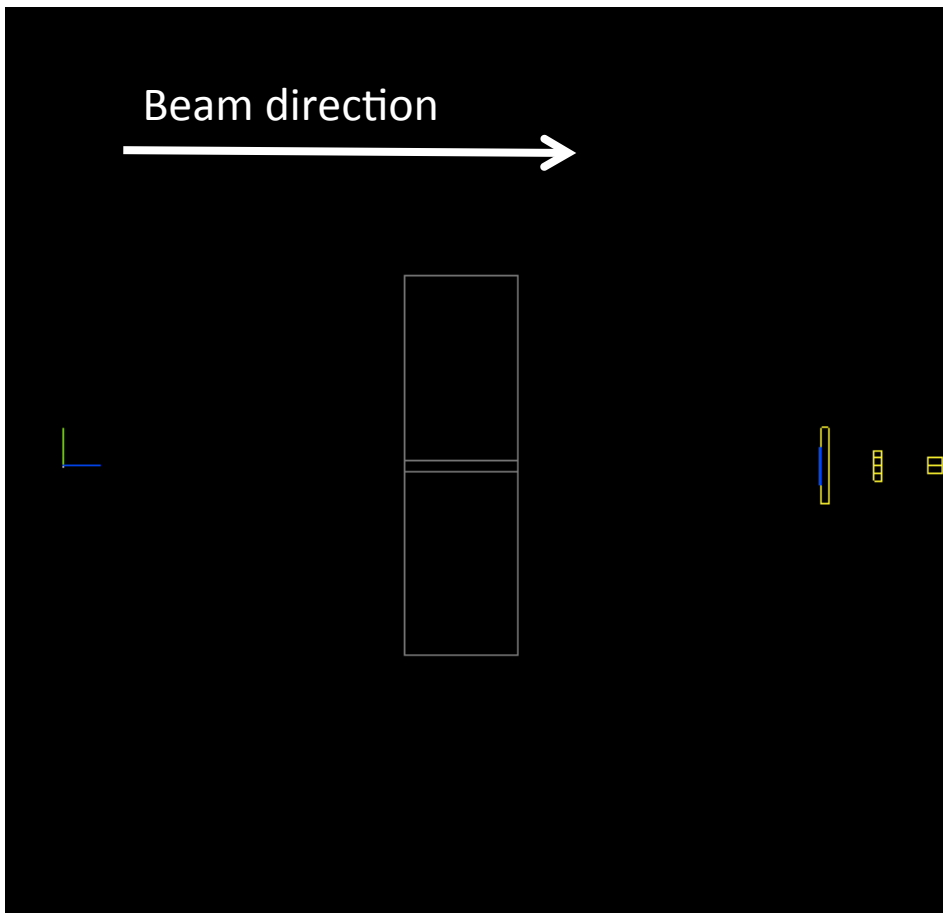

Li Target

Aperture 14cm*14cm

Concrete wall

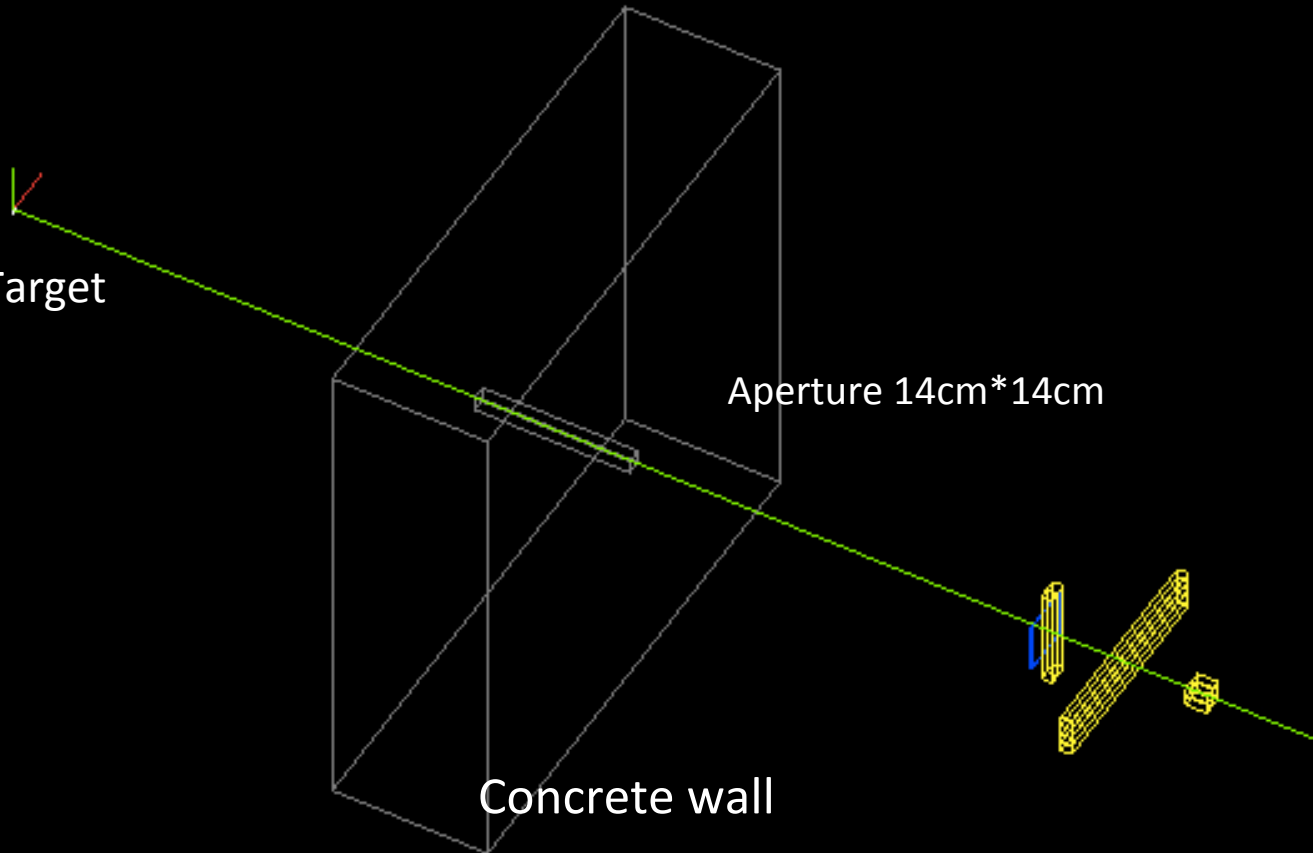

Neutron energy : 65 MeV

Number of events : 10^4

E_{th} : 1 MeV

Target – detector distance : 10 m

Gap between stations : 60 cm

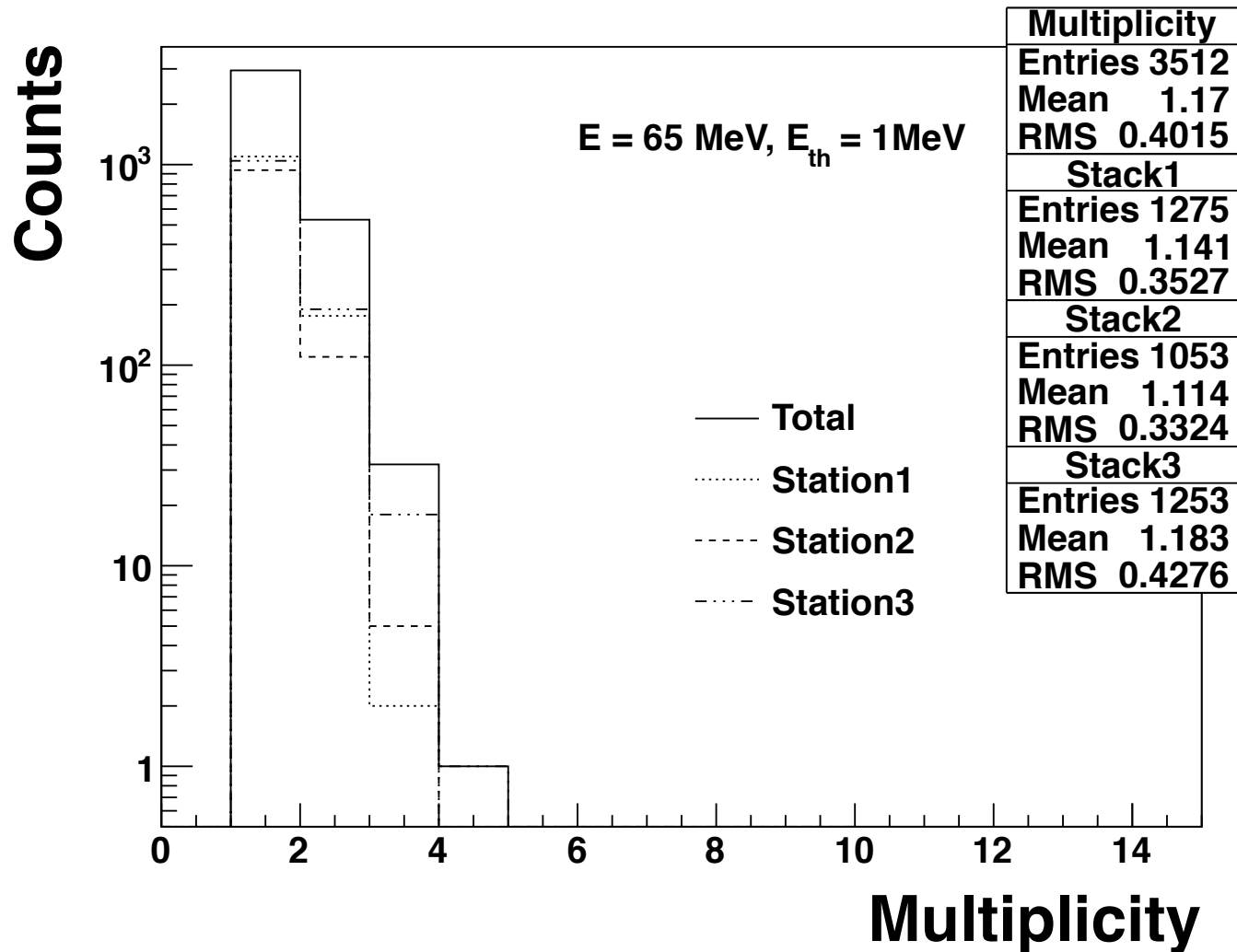

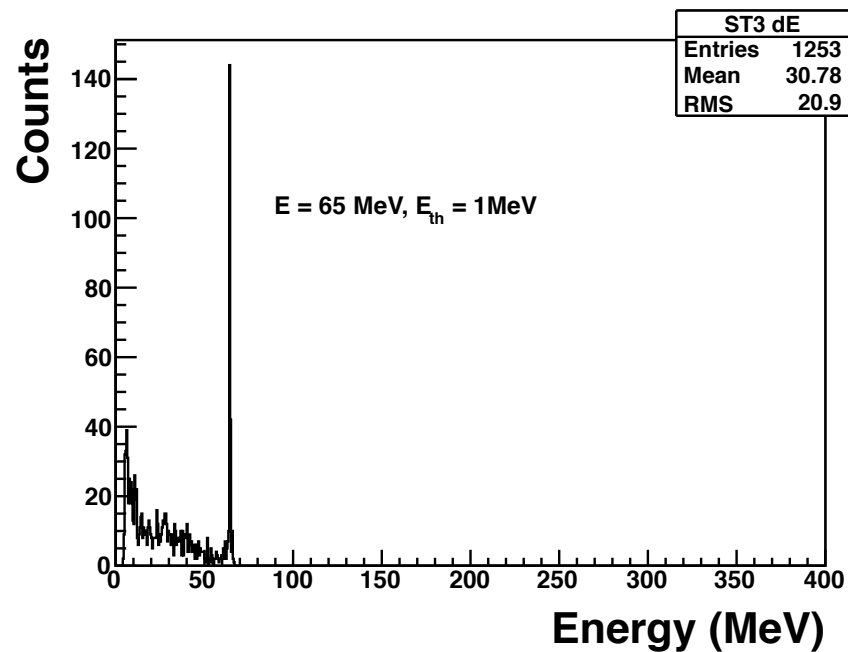
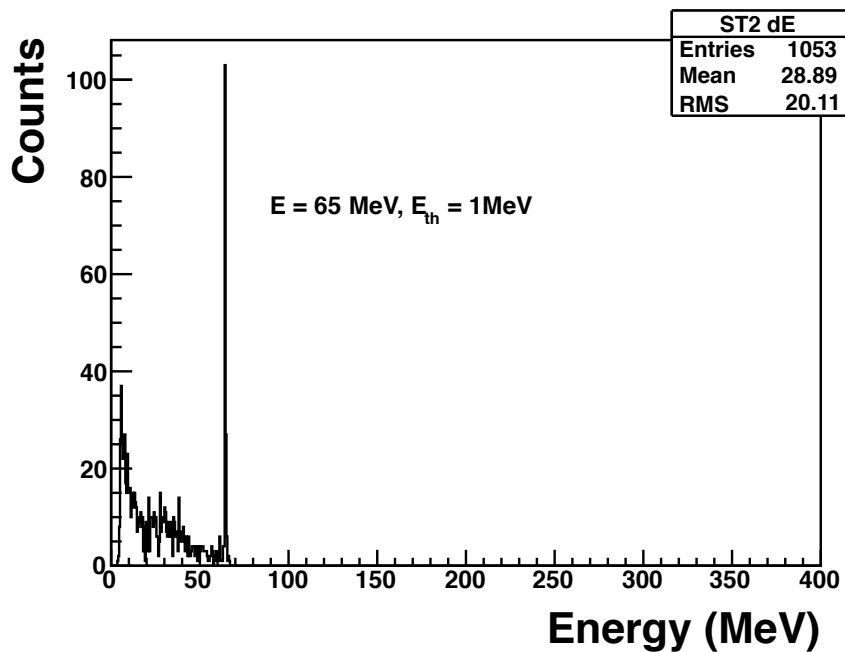
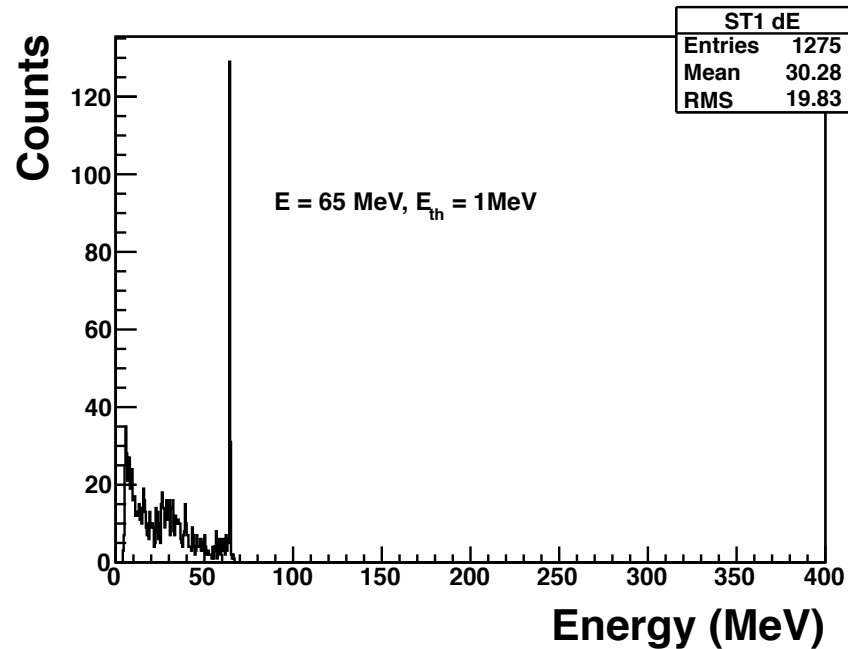
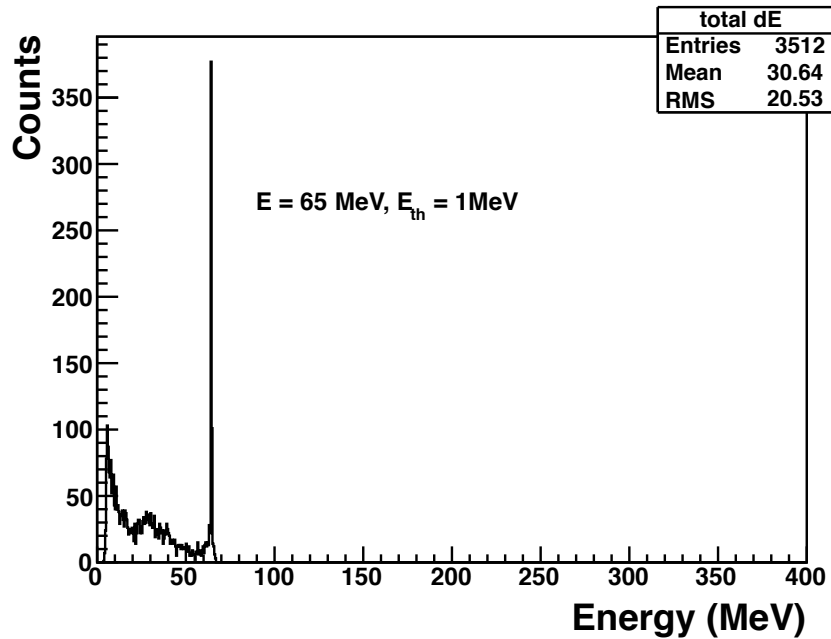

Arrival time

